

**TYPICAL CROSS SECTION
TECUMSEH AVENUE**
STATION 10+25 TO STATION 19+38

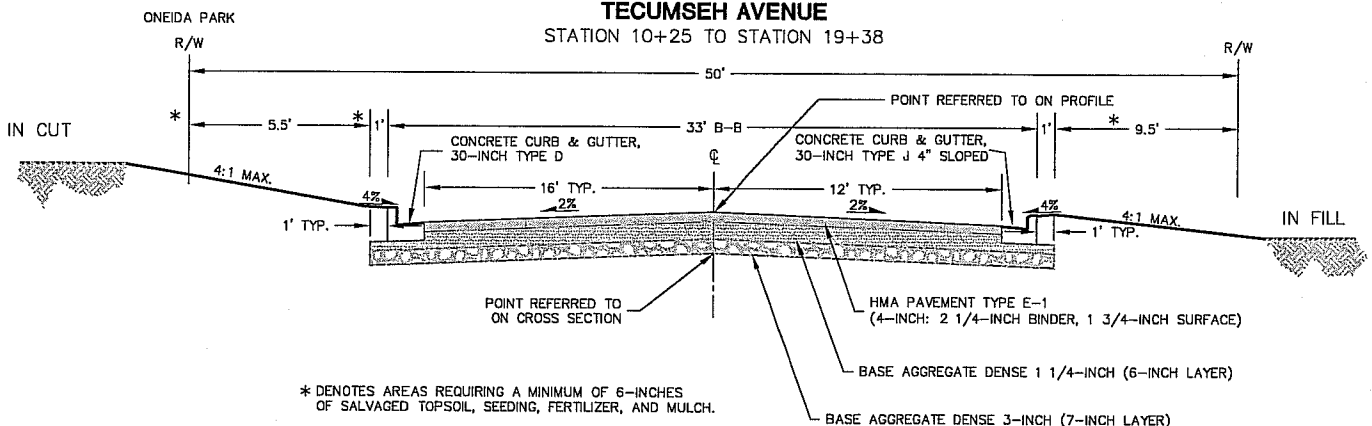

**TYPICAL CROSS SECTION
NEPONSET TRAIL**
STATION 31+75 TO STATION 35+50

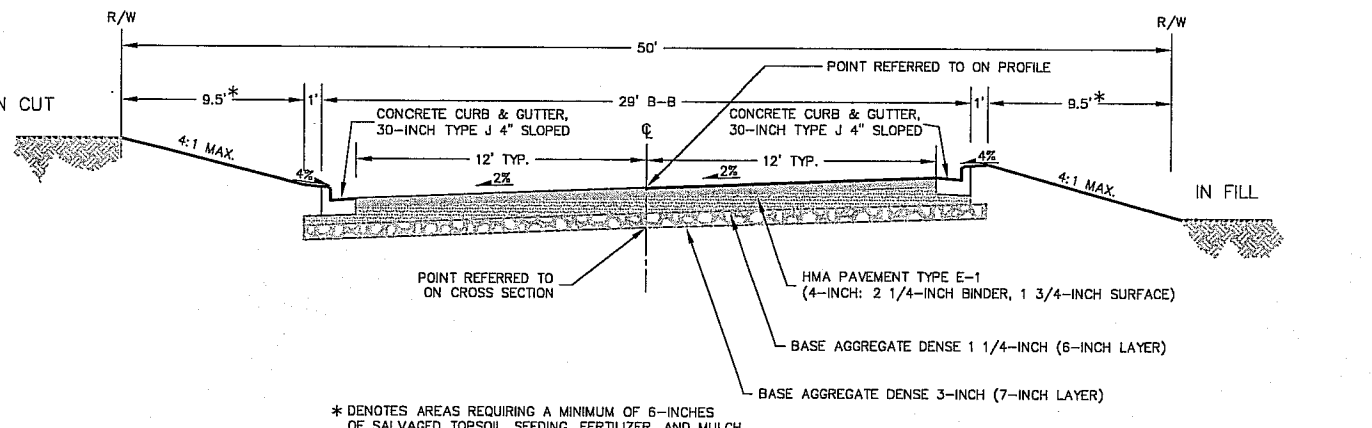



**TYPICAL CROSS SECTION
POCAHONTAS DRIVE**
STATION 64+50 TO STATION 66+00

* DENOTES AREAS REQUIRING A MINIMUM OF 6-INCHES OF SALVAGED TOPSOIL, SEEDING, FERTILIZER, AND MULCH.

* DENOTES AREAS REQUIRING A MINIMUM OF 6-INCHES OF SALVAGED TOPSOIL, SEEDING, FERTILIZER, AND MULCH.

* DENOTES AREAS REQUIRING A MINIMUM OF 6-INCHES OF SALVAGED TOPSOIL, SEEDING, FERTILIZER, AND MULCH.

CLIENT	 CITY OF MONONA 5211 SCHLUTER ROAD MONONA, WI 53716-2598 608-222-2525	SITE	2011 BELLE ISLE STREET RECONSTRUCTION	TYPICAL STREET SECTIONS					
						PROJECT NO.	4165	DRAWN BY:	BS2
				DRAWN:	12/02/10	CHECKED BY:	GB	 BT SQUARED 2830 DAIRY DRIVE MADISON, WI 53718-6751 PHONE: (608) 224-2830	FIGURE
				REVISED:		APPROVED BY:			1

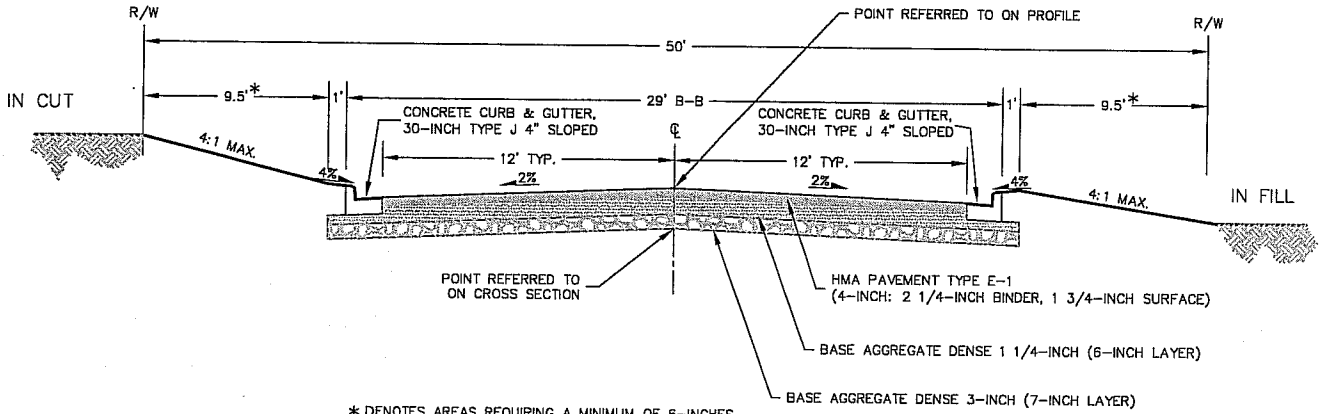

* DENOTES AREAS REQUIRING A MINIMUM OF 6-INCHES OF SALVAGED TOPSOIL, SEEDING, FERTILIZER, AND MULCH.

TYPICAL CROSS SECTION

TECUMSEH AVENUE

- STATION 2+00 TO STATION 3+30
- STATION 3+30 TO STATION 4+70* VARIES
- STATION 4+70 TO STATION 7+80
- STATION 7+80 TO STATION 9+05* VARIES
- STATION 9+05 TO STATION 10+25

NISHISHIN TRAIL NE

- STATION 20+42 TO STATION 23+25

NISHISHIN TRAIL

- STATION 40+40 TO STATION 44+15
- STATION 44+15 TO STATION 45+35* VARIES
- STATION 45+35 TO STATION 50+88

POCAHONTAS DRIVE

- STATION 60+65 TO STATION 64+50
- STATION 66+50 TO STATION 67+17

GENERAL NOTE:

ALL RESTORATION AREAS TO RECEIVE SALVAGED TOPSOIL, SEEDING #20, FERTILIZER TYPE B, AND MULCHING (MULCHING TO BE CRIMPED).

CLIENT	 CITY OF MONONA 5211 SCHLUTER ROAD MONONA, WI 53716-2598 608-222-2525	SITE	2011 BELLE ISLE STREET RECONSTRUCTION	TYPICAL STREET SECTIONS	
DRAWN: 12/02/10	CHECKED BY: GB	2			
REVISED:	APPROVED BY:				

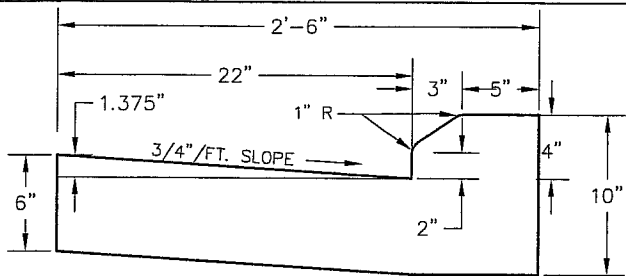

4" SLOPED CURB TYPE J SECTION

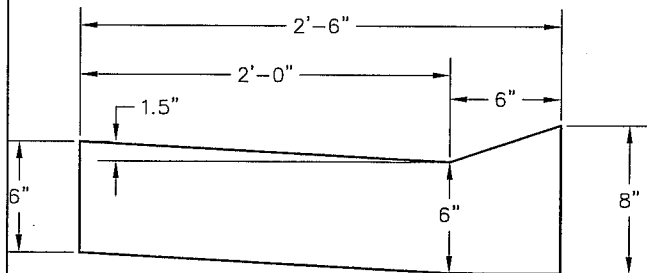

DRIVEWAY ENTRANCE CURB SECTION

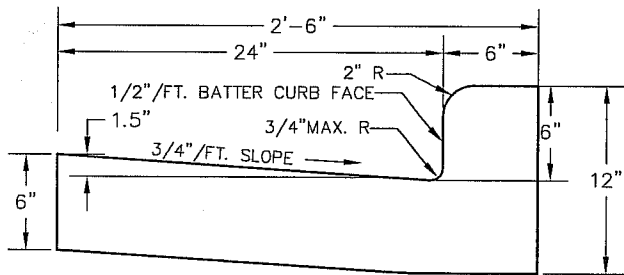

6" CURB TYPE D SECTION

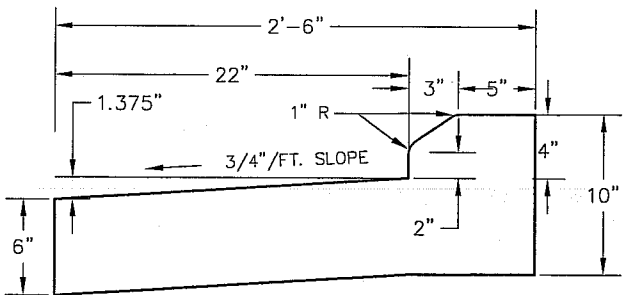

REJECT CURB SECTION

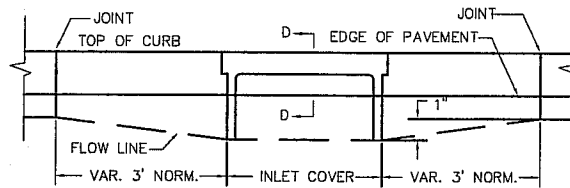

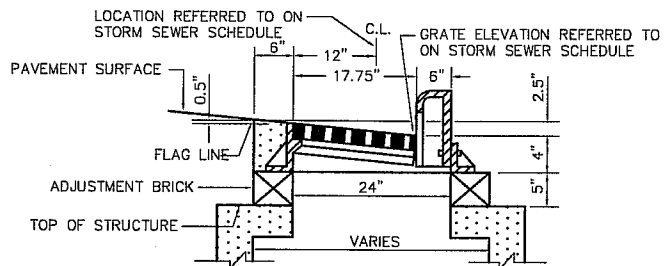

ELEVATION



SECTION D-D

DETAIL OF CURB AND GUTTER AT INLET

CLIENT	 CITY OF MONONA 5211 SCHLUTER ROAD MONONA, WI 53716-2598 608-222-2525	FILE	2011 BELLE ISLE STREET RECONSTRUCTION	CURB AND GUTTER DETAILS					
						PROJECT NO.	4165	DRAWN BY:	BS2
						DRAWN:	12/02/10	CHECKED BY:	GB
ENGINEER	REVISED:	APPROVED BY:		 BT SQUARED 2830 DAIRY DRIVE MADISON, WI 53718-6751 PHONE: (608) 224-2830	FIGURE	3			

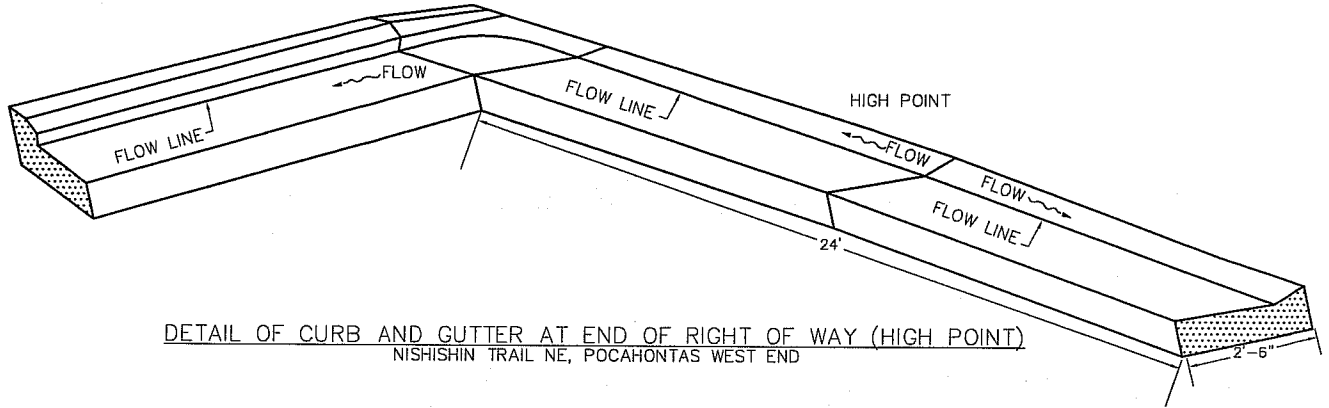

DETAIL OF CURB AND GUTTER AT END OF RIGHT OF WAY (HIGH POINT)
NISHISHIN TRAIL NE, POCAHONTAS WEST END

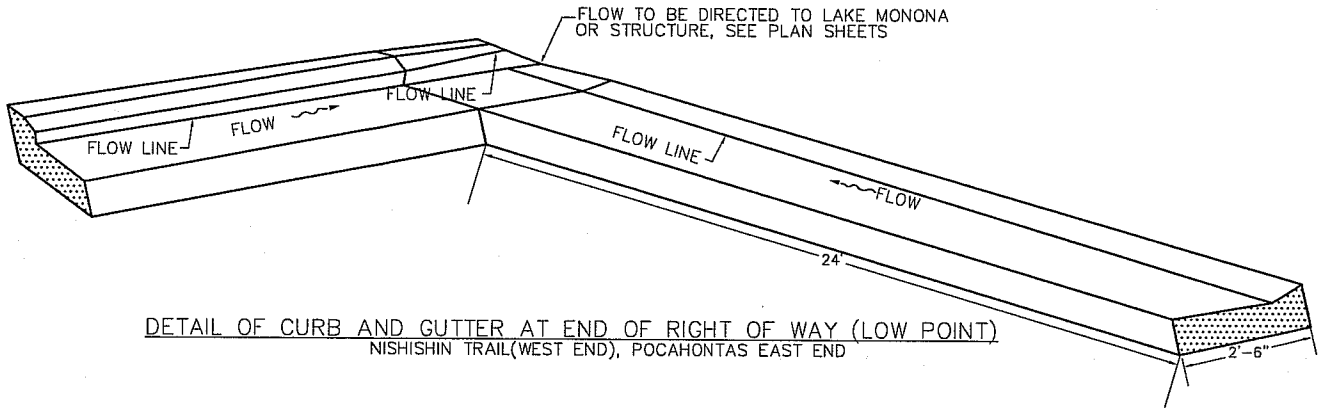

DETAIL OF CURB AND GUTTER AT END OF RIGHT OF WAY (LOW POINT)
NISHISHIN TRAIL (WEST END), POCAHONTAS EAST END



NOTES:
VALLEY GUTTER DETAIL SHALL BE USED WHEN SPECIFIED ON THE PLAN IN LIEU OF A SLOPE GUTTER AT STREET INTERSECTIONS.

VALLEY GUTTER SHALL BE MEASURED AND PAID FOR BY THE SQUARE FOOT.

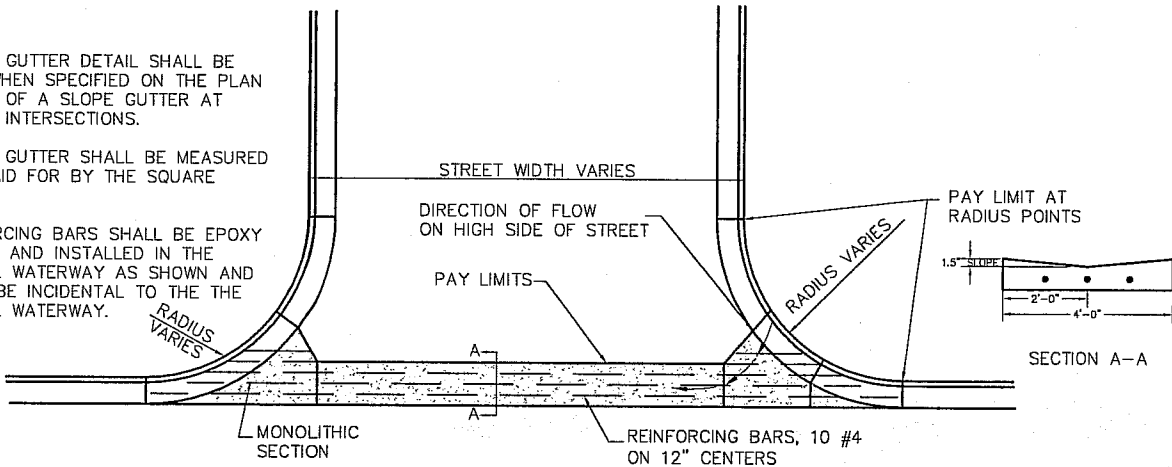
REINFORCING BARS SHALL BE EPOXY COATED AND INSTALLED IN THE SPECIAL WATERWAY AS SHOWN AND SHALL BE INCIDENTAL TO THE SPECIAL WATERWAY.



VALLEY GUTTER DETAIL
NISHISHIN TRAIL & NISHISHIN TRAIL NE INTERSECTION

CLIENT	 CITY OF MONONA 5211 SCHLUTER ROAD MONONA, WI 53716-2598 608-222-2525	SITE	2011 BELLE ISLE STREET RECONSTRUCTION	CURB AND GUTTER DETAILS	
				PROJECT NO.	4165
	DRAWN:	12/02/10	CHECKED BY:	GB	 2830 DAIRY DRIVE MADISON, WI 53718-6751 PHONE: (608) 224-2830
	REVISED:		APPROVED BY:		
					4

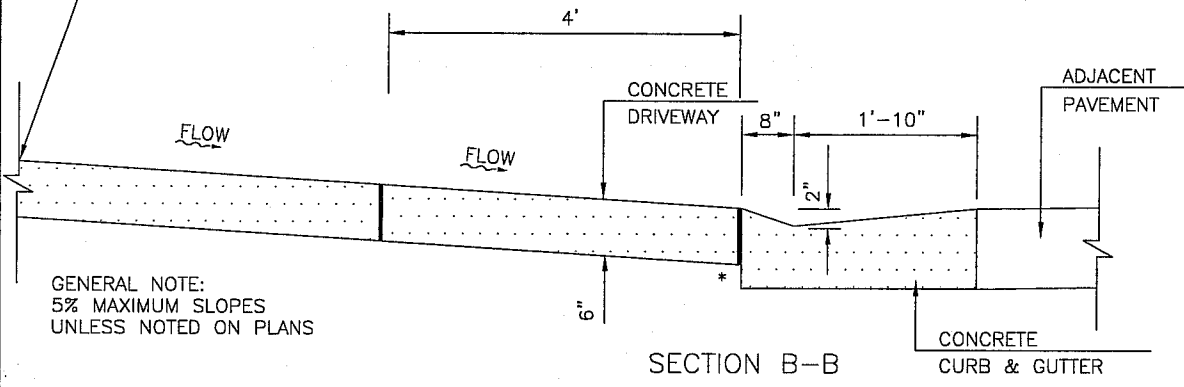

SEE PLAN SHEETS FOR
SAWCUT MATCH LOCATIONS

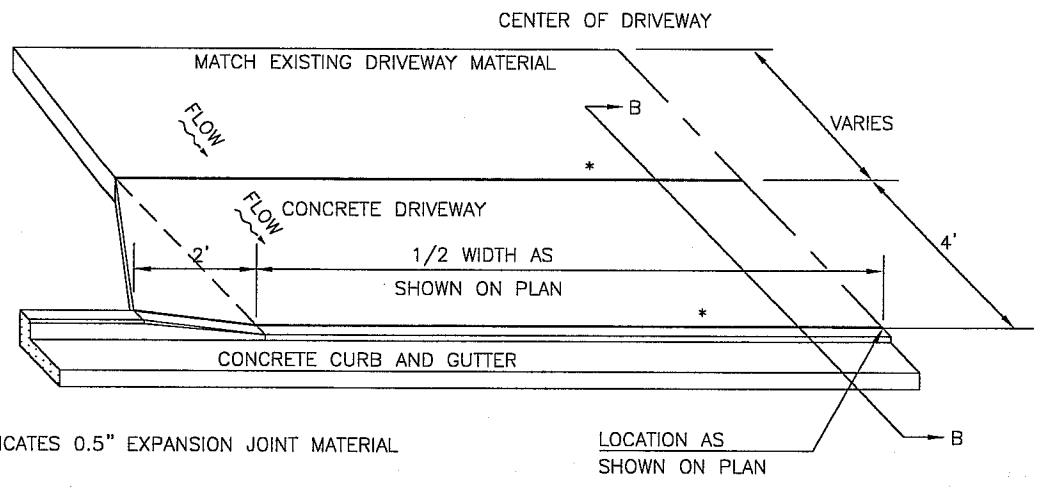

SECTION B-B



FRONT PITCH DRIVEWAY RECONSTRUCTION
TYPE 1 DRIVEWAY

CLIENT		CITY OF MONONA 5211 SCHLUTER ROAD MONONA, WI 53716-2598 608-222-2525		SITE	2011 BELLE ISLE STREET RECONSTRUCTION		FRONT PITCH DRIVEWAY TYPE 1		
		PROJECT NO.	4165		DRAWN BY:	BS2	ENGINEER	 BT SQUARED 2830 DAIRY DRIVE MADISON, WI 53718-6751 PHONE: (608) 224-2830	FIGURE
		DRAWN:	12/02/10		CHECKED BY:	GB			5
		REVISED:	12/06/10		APPROVED BY:				

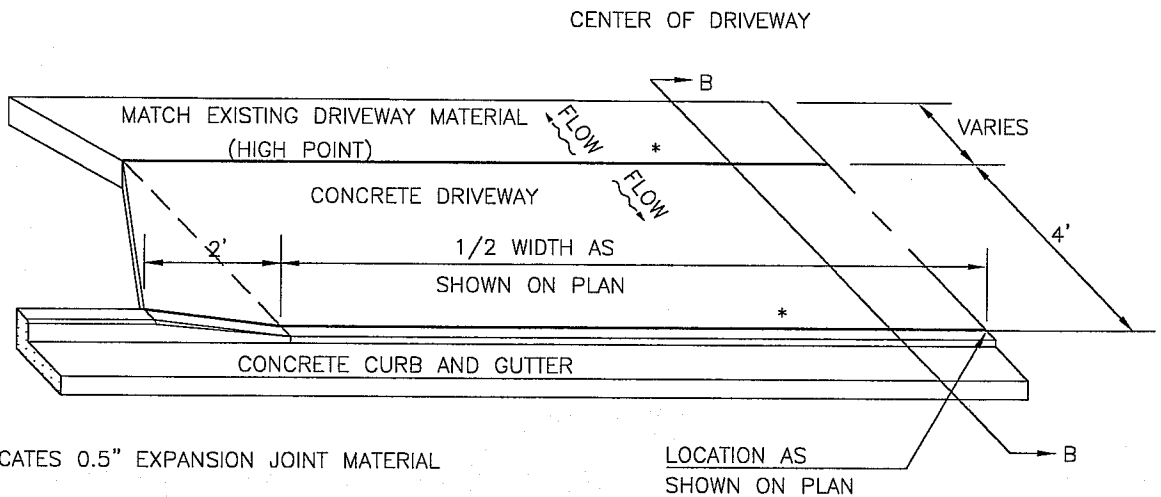
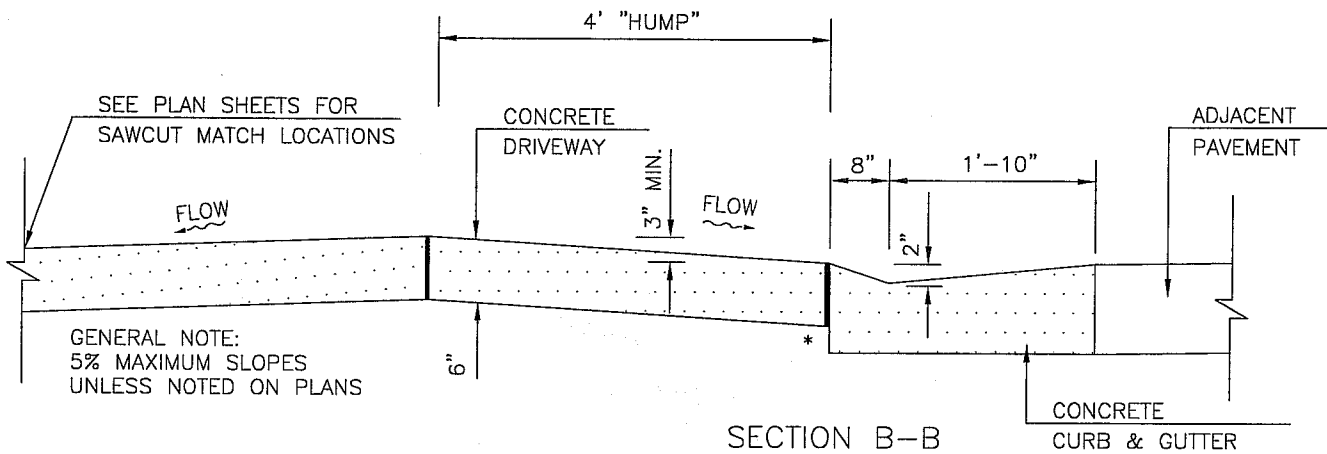



BACK PITCH DRIVEWAY RECONSTRUCTION
TYPE 2 DRIVEWAY

* INDICATES 0.5" EXPANSION JOINT MATERIAL

LOCATION AS SHOWN ON PLAN

CLIENT	 CITY OF MONONA 5211 SCHLUTER ROAD MONONA, WI 53716-2598 608-222-2525	FILE	2011 BELLE ISLE STREET RECONSTRUCTION	FRONT PITCH DRIVEWAY TYPE 2	
				PROJECT NO. 4165	DRAWN BY: BS2
DRAWN: 12/02/10	CHECKED BY: GB	ENGINEER	6		
REVISED: 12/06/10	APPROVED BY:				

BELLE ISLE STREETS
2011 STREET AND UTILITY IMPROVEMENTS

-  EXISTING 3/4" DIA. IRON ROD
-  EXISTING 1" DIA. IRON PIPE
-  EXISTING 2" DIA. IRON PIPE

N

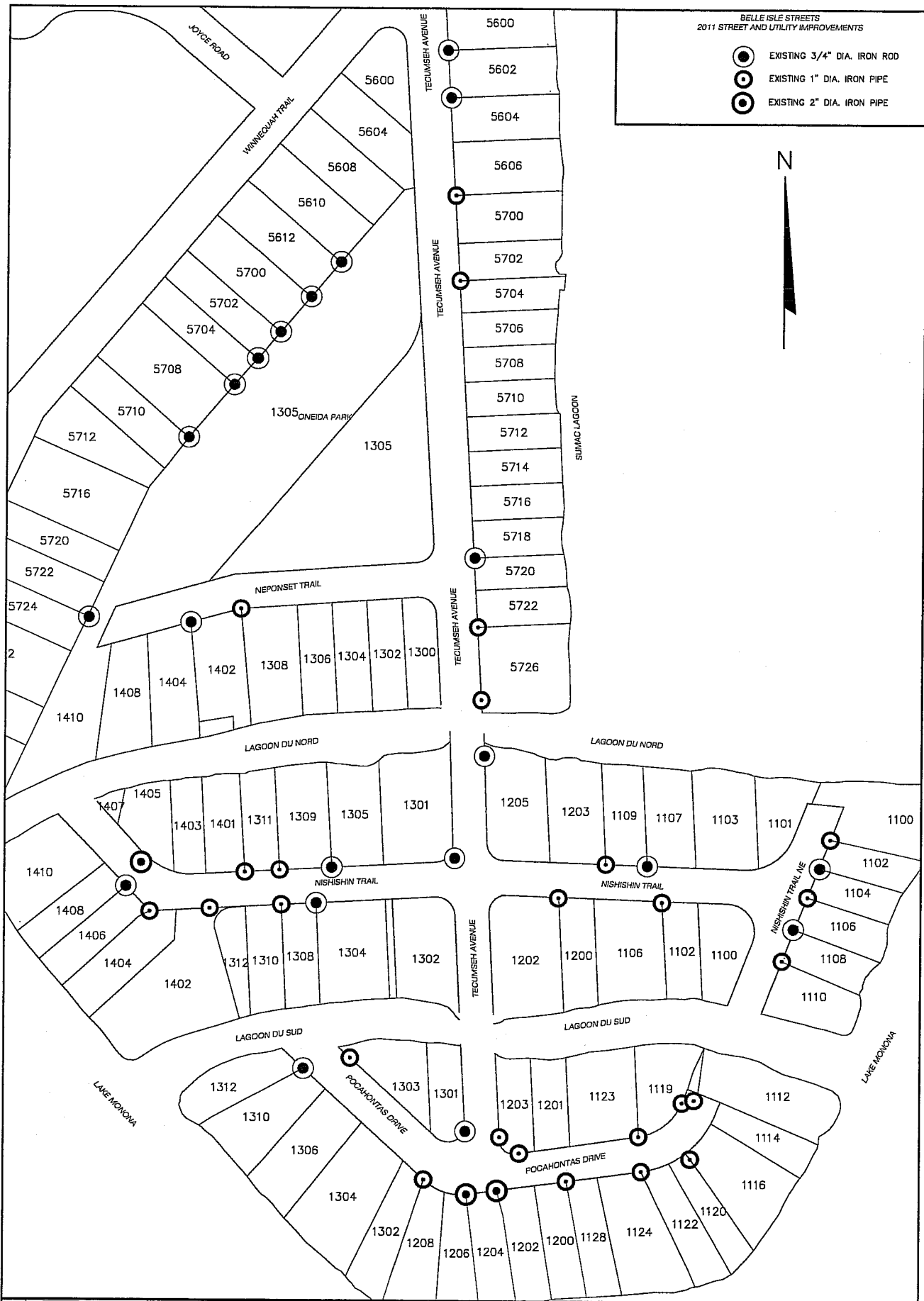

CLIENT  CITY OF MONONA
5211 SCHLUTER ROAD
MONONA, WI 53716-2598
608-222-2525

SITE 2011 BELLE ISLE STREET
RECONSTRUCTION

PROPERTY IRON LOCATIONS

PROJECT NO. 4165
DRAWN: 12/02/10
REVISED:

DRAWN BY: BS2
CHECKED BY: GB
APPROVED BY:

ENGINEER  BT SQUARED
2830 DAIRY DRIVE MADISON, WI 53718-6751
PHONE: (608) 224-2830

FIGURE
7